

ISO TOOL™

Framtidens dubbhålsverktyg!

Nine9
i-Center.

*Skär med två skäreppor = ekonomiskt .
En skärsort = täcker hela Ert behov.
Bifogad skärdata = lätt att komma igång
Slipade skär = maximal precision samt lättskärande.
Bara att byta skär = slut på tidskrävande omslipning, samt
inmätningar efter borrhöjning
Patenterad och stabil inspänning av skäret.
Hög skärdata = produktivt. (Vc:80-300m/min)
Belagda hårdmetallskär = lång livslängd.
Invändig kylning i hållaren = bra spånavgång.*

Hållare

Från* 690Kr



**Gårdagens
dubbhålsbör
i HSS**



Skär

Från 328Kr

DIN332R

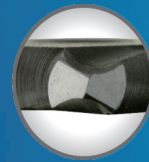

Ø2,0
Ø2,5
Ø3,15
Ø4,0
Ø5,0
Ø6,3
Ø8,0
Ø10,0

DIN332B+A



ANSI 60°



ISO TOOL AB

Tel: 044-245570

Estridsväg 17

291 65 Kristianstad

Fax: 044-245540

www.isotool.se

e-mail: info@isotool.se

* Gäller vid köp av 2st passande skär i strl. 2,0mm till 3,15mm eller vid 1st passande skär i strl. 4,0mm till 10,0mm

Nine⁹®

indexable Center Drill

- *Highly Efficient Tools*
- *No Re-setting, No Resharpening*
- *Time Saving*
- *Long Tool Life*
- *Improve your Process Performance*

i-center®

<http://www.jic-tools.com.tw>

i-center indexable center drill (patent pending)

First Indexable center drill in the world.

Shortens set up time and center drilling time.

Increases tool life which reduces tooling costs.

Special forms are possible.



2009-08
Cat. No.01

The “i-center ” is a trademark of Nine9, the developer of the first indexable center drill. For the first time, Nine9’s “i-center ” patent-pending design provides the benefit of solid carbide cutting parameters while delivering -

■ **High Speed, High Feed Rate**

High Performance speed and feed can be reached thanks to the special ground insert and ridged holder design. For example, for drilling alloy steel is 6000 rpm and Feed rate 600 mm/min. (0.1mm/rev.)

■ **Easy Tool Length Setting**

The axial position accuracy of the insert is 0.05 mm. It is not necessary to reset the tool length again while changing insert or cutting edge.

■ **Excellent Repeatability**

The insert is position by two fixed pin and clamped by one insert screw at the center. The positioning repeatability of the insert within 0.02 mm in radial direction, thus ensuring conformity to any National Standard.

■ **Extended Tool Life**

Coolant can be supplied through the center of the holder to increase performance and extend tool life. Insert geometry, grades and coating process are specifically engineered for centering applications.

■ **Universal and Easily Integrated with Special Tools**

The tool holder is made of high alloy steel, hardened and ground to h6 tolerances with a flat. It’s easy for stationary tool and rotating tool. Special combinations tools available upon request. (see page 6)



• Application on turning machine.



• High pressure coolant can be supplied through center directly to tip of center drill insert.

i-Center Tool holder

Features:

- ⊙ Made of High alloy steel and hardened.
- ⊙ Special holders are available on request.



Order No.	Part No.	IC	Ød	L1	L2	ØD	Screw	Key
00-99616-IC12-16	SB16-IC12	12	16	48	36	21	NS-30072 2.0 Nm	NK-T9
00-99616-IC16-16	SB16-IC16	16	16	48	43	27	NS-35080 2.5 Nm	NK-T15
00-99616-IC20-20	SB20-IC20	20	20	50	60	32	NS-50120 5.5 Nm	NK-T20
00-99616-IC25-25	SB25-IC25	25	25	56	65	43	NS-50120 5.5 Nm	NK-T20

Order No.	Part No.	IC	Ød	L1	L2	ØD	Screw	Key
00-99616-IC12-5/8	SB5/8"-IC12	12	5/8"	48	36	21	NS-30072 2.0 Nm	NK-T9
00-99616-IC16-5/8	SB5/8"-IC16	16	5/8"	48	43	27	NS-35080 2.5 Nm	NK-T15
00-99616-IC20-3/4	SB3/4"-IC20	20	3/4"	50	60	32	NS-50120 5.5 Nm	NK-T20
00-99616-IC25-1	SB1"-IC25	25	1"	56	65	43	NS-50120 5.5 Nm	NK-T20

i-Center. Indexable center insert

Features:

- ⊙ NC 2033: K20F grade carbide insert and TiAlN coated for carbon steel, alloy steel, high alloy steel, cast iron and Al, Al-alloy, Cu, Cu-alloy.
- ⊙ 2 cutting edges, high performance for center drilling.
- ⊙ Metric sizes: DIN 332 A+B, DIN 332 R, 2~10 mm
- ⊙ Inch sizes: ANSI (BS) #2 ~10
- ⊙ Special forms are available on request.

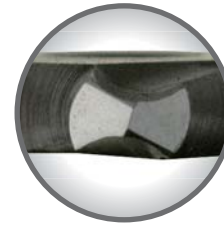

2 cutting edges



• DIN332 Form R

Parts No.	d1		d2	L1	L2	R		IC
	min.	max.						
I9MT12T2R0200-NC2033	2.00	+0.14 0	5.0	5.3	6.72	5.0	6.3	12
I9MT12T2R0250-NC2033	2.50		6.3	6.7	8.29	6.3	8.0	
I9MT12T2R0315-NC2033	3.15	+0.18 0	8.0	8.5	9.94	8.0	10.0	16
I9MT1603R0400-NC2033	4.00		10.0	10.6	12.84	10.0	12.5	
I9MT1603R0500-NC2033	5.00		12.5	13.2	14.78	12.5	16.0	20
I9MT2004R0630-NC2033	6.30	+0.22 0	16.0	17.0	18.83	16.0	20.0	
I9MT2004R0800-NC2033	8.00		20.0	21.2	21.2	20.0	25.0	25
I9MT2506R1000-NC2033	10.00		25.0	26.5	26.5	25.0	31.5	

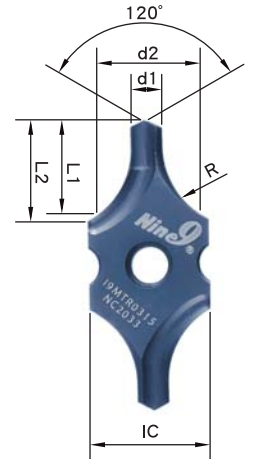

• DIN332 Form A+B

Parts No.	d1		d2	d3	L1	L2	L3	IC	
	min.	max.							
I9MT12T2B0200-NC2033	2.00	+0.14 0	4.25	6.3	2.5	+0.8 0	4.3	4.9	12
I9MT12T2B0250-NC2033	2.50		5.3	8	3.1	+1.0 0	5.5	6.8	
I9MT12T2B0315-NC2033	3.15	+0.18 0	6.7	10	3.9	+1.2 0	7.4	9.0	16
I9MT1603B0400-NC2033	4.00		8.5	12.5	5.0		9.5	10.6	
I9MT1603B0500-NC2033	5.00		10.6	16	6.3	11.7	13.3	20	
I9MT2004B0630-NC2033	6.30	+0.22 0	13.2	18	8.0	14.6	15.9		
I9MT2004B0800-NC2033	8.00		17.0	20	10.1	18.6	19.4	25	
I9MT2506B1000-NC2033	10.00		21.2	25	12.8	23.2	24.3		

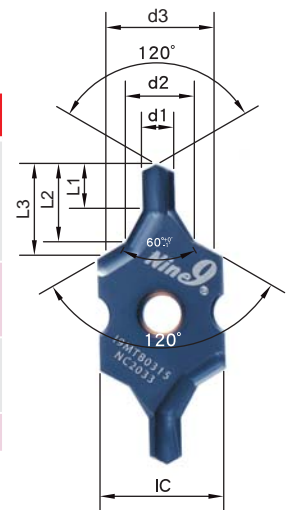

• ANSI 60°

Parts No.	Size	d1		d2		L1			L2	IC	
			mm		mm		mm				
I9MT12T2A2-NC2033	#2	5/64	1.98	+0.14 0	3/16	4.76	5/64	1.98	+0.8 0	4.4	12
I9MT12T2A3-NC2033	#3	7/64	2.78		1/4	6.35	7/64	2.78	+1.0 0	5.9	
I9MT12T2A4-NC2033	#4	1/8	3.18	+0.18 0	5/16	7.94	1/8	3.18	+1.2 0	7.3	16
I9MT1603A5-NC2033	#5	3/16	4.76		7/16	11.11	3/16	4.76		10.3	
I9MT2004A6-NC2033	#6	7/32	5.56		1/2	12.7	7/32	5.56	11.8	20	
I9MT2004A7-NC2033	#7	1/4	6.35	+0.22 0	5/8	15.88	1/4	6.35	14.6		
I9MT2004A8-NC2033	#8	5/16	7.94		3/4	19.05	5/16	7.94	+1.4 0	17.6	25
I9MT2506A10-NC2033	#10	3/8	9.53		0.98"	25.0	3/8	9.53	22.9		

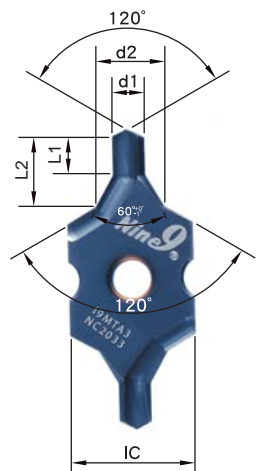

i-Center Cutting data

Attention:

- For $d1 < 4$ mm or size #5, be sure the center misalignment is less than 0.05mm.
- If the misalignment of the turret center of the CNC lathe is above 0.15mm, please use the Center Height Adjusting Sleeve (see page 6.)
- For low spindle speed special purpose machines or lathes, lower spindle speed is allowed but the feed rate should be kept.

• $\varnothing 2 \sim \varnothing 4$ (#2~#5)

Work piece material	f		f (mm/rev)				Cutting fluid
	Vc (m/min)	d1	$\varnothing 2$ (#2)	$\varnothing 2.5$ (#3)	$\varnothing 3.15$ (#4)	$\varnothing 4$ (#5)	
Carbon steel C<0.3%	60-70-80		(S=11140 rpm) 0.03-0.05-0.06	(S=8912 rpm) 0.04-0.06-0.08	(S=7073 rpm) 0.08-0.10-0.12	(S=5570 rpm) 0.08-0.12-0.14	emulsion
Carbon steel C>0.3%	50-60-70		(S=9549 rpm) 0.03-0.04-0.05	(S=7639 rpm) 0.04-0.06-0.08	(S=6063 rpm) 0.08-0.10-0.12	(S=4774 rpm) 0.08-0.12-0.14	emulsion
Low alloy steel C<0.3%	45-55-65		(S=8753 rpm) 0.02-0.03-0.05	(S=7002 rpm) 0.03-0.05-0.07	(S=5557 rpm) 0.06-0.08-0.10	(S=4376 rpm) 0.06-0.08-0.10	emulsion
High alloy steel C>0.3%	40-50-60		(S=7957 rpm) 0.01-0.02-0.04	(S=6366 rpm) 0.02-0.04-0.06	(S=5052 rpm) 0.04-0.06-0.08	(S=3978 rpm) 0.04-0.06-0.08	emulsion
Cast iron	50-60-70		(S=9549 rpm) 0.02-0.04-0.06	(S=7639 rpm) 0.04-0.06-0.08	(S=6063 rpm) 0.06-0.08-0.10	(S=4774 rpm) 0.06-0.08-0.10	dry
Al, and non-ferrous metal	100-150-200		(S=23873 rpm) 0.01-0.02-0.04	(S=19098 rpm) 0.02-0.03-0.05	(S=15157 rpm) 0.02-0.04-0.06	(S=11936 rpm) 0.02-0.04-0.06	emulsion

• $\varnothing 5 \sim \varnothing 10$ (#6~#10)

Work piece material	f		f (mm/rev)				Cutting fluid
	Vc (m/min)	d1	$\varnothing 5$ (#6)	$\varnothing 6.3$ (#7)	$\varnothing 8$ (#8)	$\varnothing 10$ (#10)	
Carbon steel C<0.3%	60-70-80		(S=4456 rpm) 0.10-0.12-0.16	(S=3536 rpm) 0.10-0.14-0.16	(S=2785 rpm) 0.12-0.15-0.18	(S=2228 rpm) 0.14-0.18-0.20	emulsion
Carbon steel C>0.3%	50-60-70		(S=3819 rpm) 0.10-0.12-0.16	(S=3031 rpm) 0.10-0.14-0.16	(S=2387 rpm) 0.12-0.15-0.18	(S=1909 rpm) 0.14-0.18-0.20	emulsion
Low alloy steel C<0.3%	45-55-65		(S=3501 rpm) 0.08-0.10-0.12	(S=2778 rpm) 0.08-0.12-0.14	(S=2188 rpm) 0.10-0.14-0.16	(S=1750 rpm) 0.12-0.16-0.20	emulsion
High alloy steel C>0.3%	40-50-60		(S=3183 rpm) 0.06-0.08-0.10	(S=2526 rpm) 0.08-0.10-0.12	(S=1989 rpm) 0.10-0.14-0.16	(S=1591 rpm) 0.10-0.14-0.16	emulsion
Cast iron	50-60-70		(S=3819 rpm) 0.08-0.10-0.12	(S=3031 rpm) 0.08-0.12-0.14	(S=2387 rpm) 0.10-0.14-0.16	(S=1909 rpm) 0.12-0.16-0.18	dry
Al, and non-ferrous metal	100-150-200		(S=9549 rpm) 0.04-0.06-0.08	(S=7578 rpm) 0.04-0.06-0.08	(S=5968 rpm) 0.06-0.08-0.10	(S=4774 rpm) 0.06-0.08-0.10	emulsion

Undeniable benefits of **i-center**

i-center is the unique solution in the world to up grade the center drill process into the indexable generation leaving HSS and solid carbide centering as ancient history.

Example of comparison:

Work piece: Low carbon alloy steel, 850 N/mm²

Diameter of tool: Ø3.15 mm Depth of drilling: 7.2 mm

Machine: Vertical Machining Center, BT40 with internal coolant

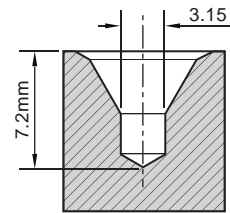

i-center

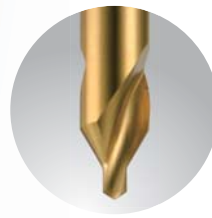

HSS
Center drill

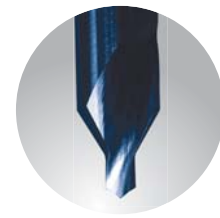

Solid carbide
center drill

		i-center	HSS Center drill	Solid carbide center drill
Cutting speed	m/min.	65	17	65
Spindle speed	r.p.m.	6570	1718	6570
Feed rate f =	mm/rev.	0.1	0.02	0.1
Feed rate F=	mm/min.	657	34.4	657
Coolant	Emulsion	External / Internal	External	External
Drilling time	sec.	0.65	12.5	0.65
Holes of drilling per edge		3000	200	2000

Profit by making the right choice

- ⊙ High speed and feed rates of the i-center reduce cutting time.
- ⊙ The unique design of i-center increases tool life and reduces change over time.
- ⊙ Together these attributes lower cost and increase your profits!

■ Nine9 i-center
 ■ HSS center drill
 ■ Solid carbide center drill

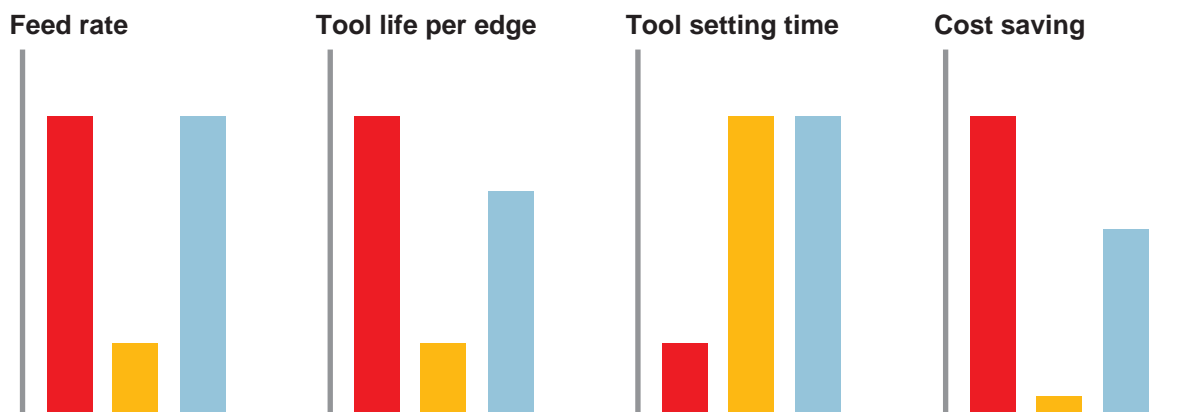

Application of i-Center.

- For shaft end machining.

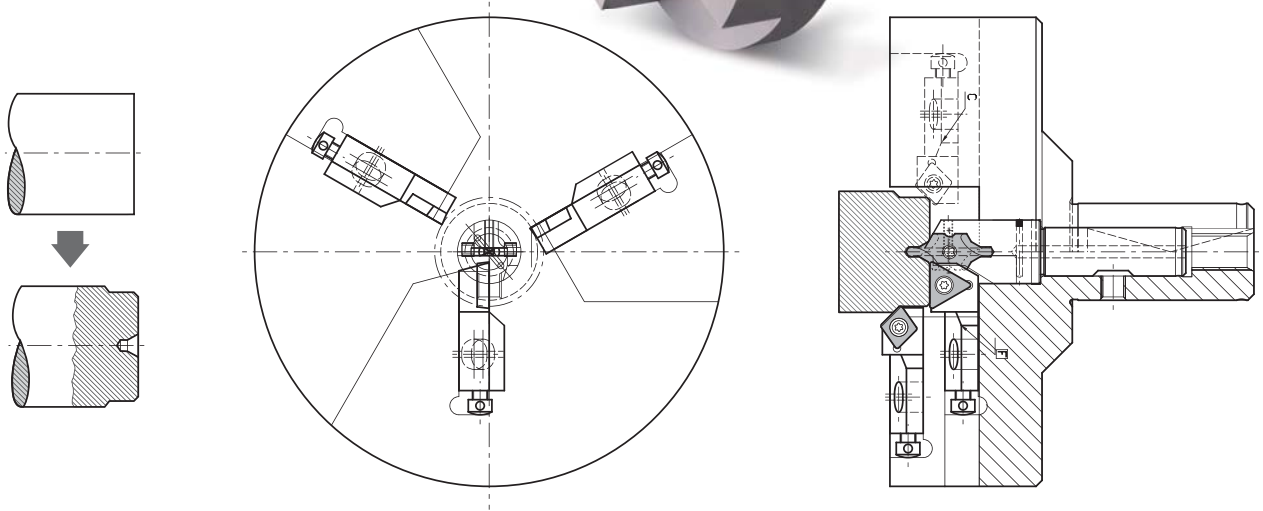

Center Height Adjusting Sleeve

Principle:

Designed for adjusting **Center Height** of center drills, NC spot drills, reamers and taps on the CNC lathes.

Applications:

- Used when the CNC lathes is needed to adjust the center height.
- For clamping 16 mm side lock shank tool holder or cutting tool, and this sleeve can be clamped in VDI 40, VDI 50 E2 tool holders, and other type of internal turning tool holders.
- Center height adjusting range: ± 0.15 mm.
- Total axial movement is 6mm.

Clamping



**For use on
CNC lathes**

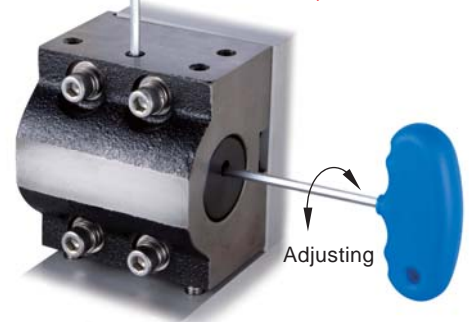

Adjusting

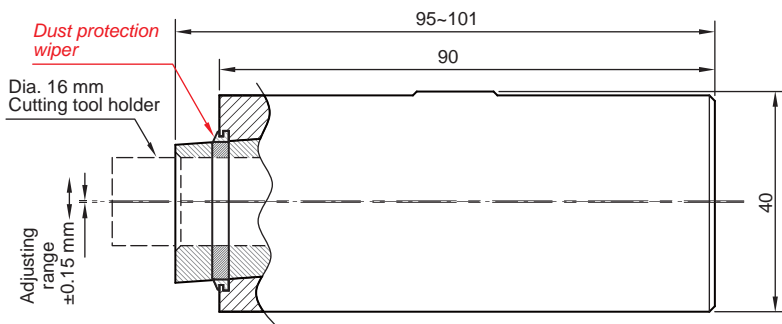

Locking Screw: M8
Order No.:
00-99600-400

Distributor :